

MeshDynamics

Dynamic control of Ad hoc Wireless Networks

www.MeshDynamics.com

Suggestion: Save Document to Local drive for faster viewing.

MeshDynamics

- Wireless LAN/MAN/PAN OEM solution provider
- Subsidiary of Advanced Cybernetics Group, Inc.
- Website: www.meshdynamics.com

Advanced Cybernetics Group, Inc.

- Embedded Software Provider since 1992
- Proven expertise in adaptive and distributed control systems.
- Approved DoD contractor, OEM supplier for Adept, IBM, Staubli.
- Website: www.advancedcybernetics.com



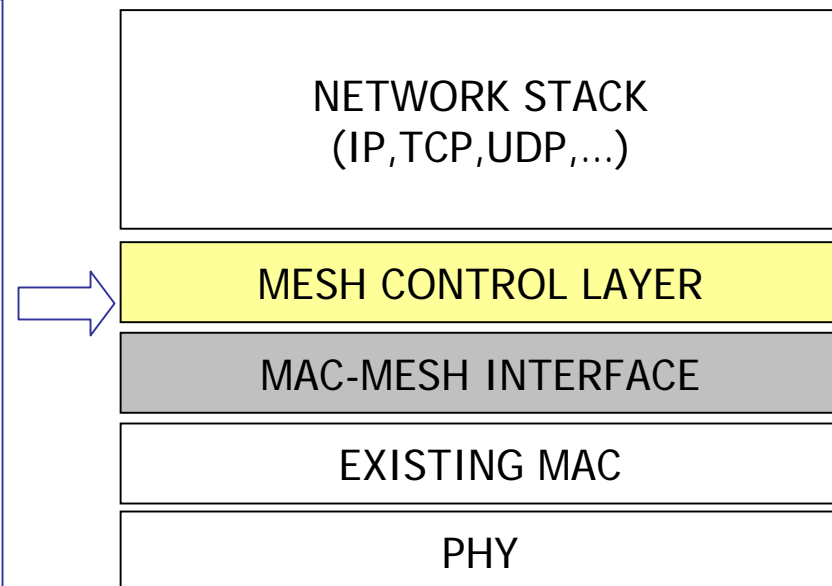
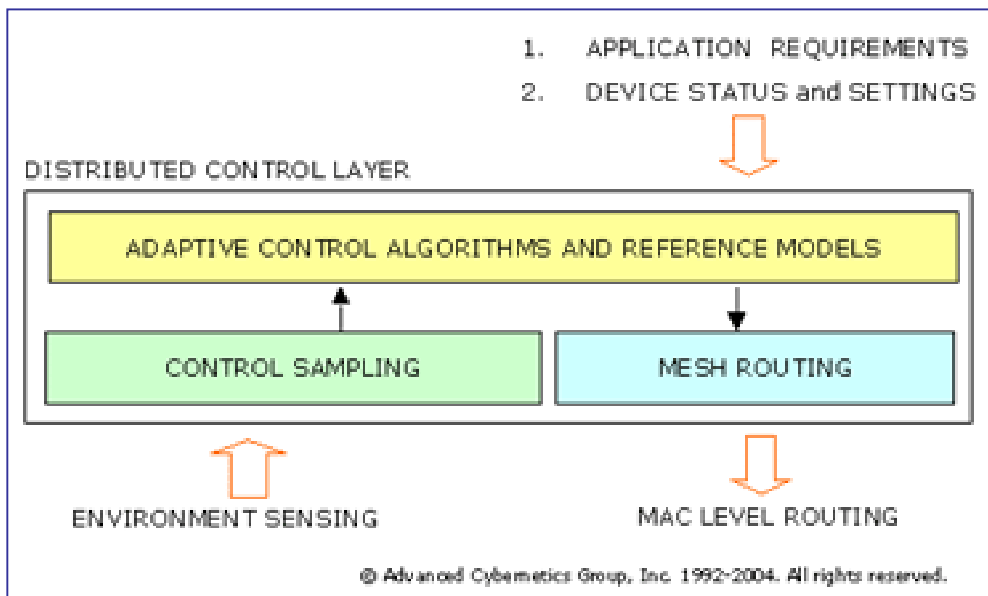





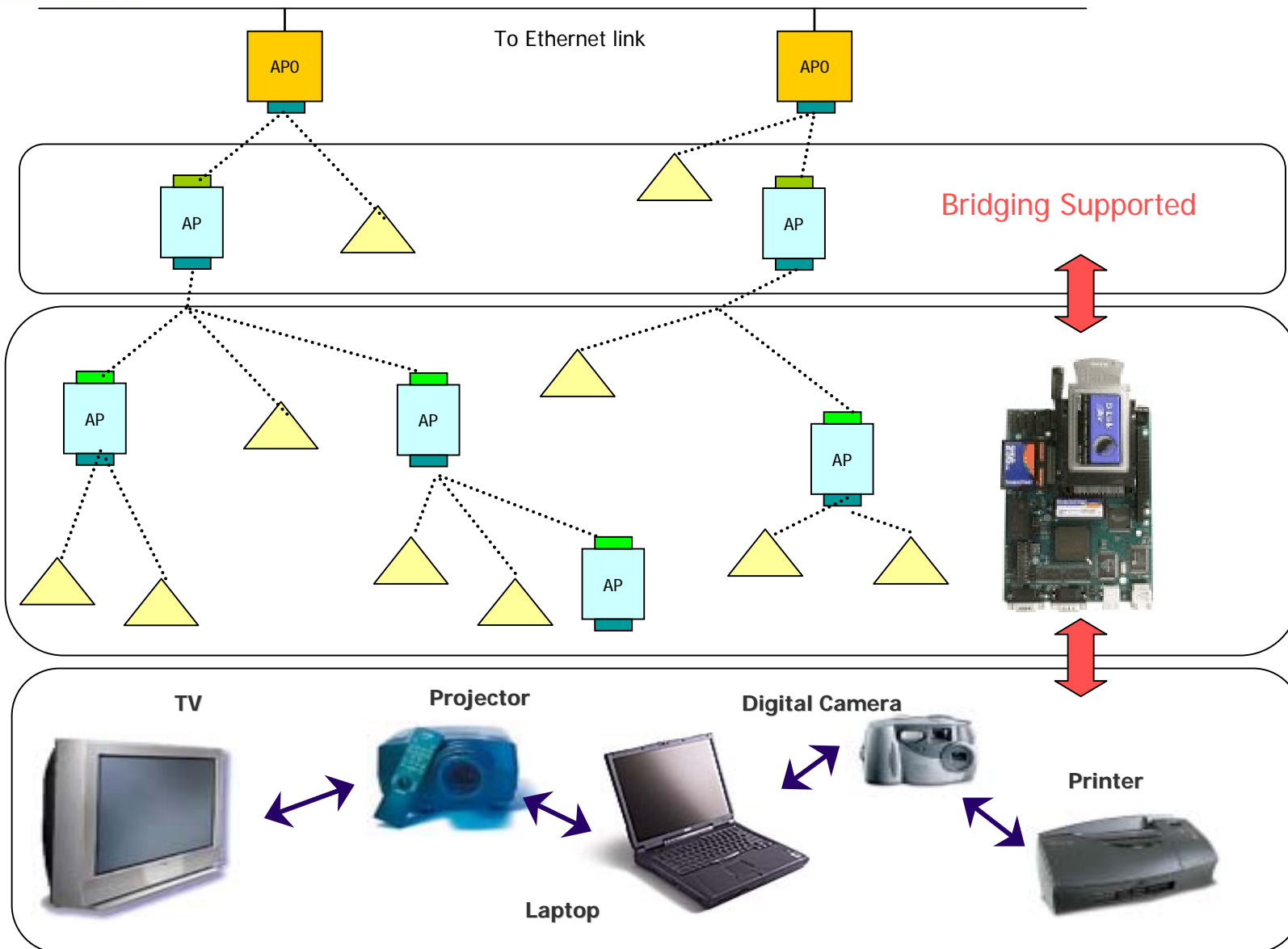







































- Software only solution, 60KB Small Footprint
- Mesh functionality implemented and OEM ready.

MeshControl™ Overlay Offerings



OEM Ready Software Control Layer Features		WLAN	WMAN	WPAN
	Small 60Kb low power footprint: can run on wireless chip *			
	Distributed Control for scalable and stable solutions *			
	No Site Survey requirements- out-of-box connectivity			
	Software is Radio Hardware and MAC Protocol agnostic *			
	Bridging between protocols (802.16-802.11-802.15) *			
	Self Healing, Self Configuring, Auto Discovery			
	Adapt/adjust network topology for latency/ throughput *			
	Auto Load Balancing with no special client software *			
	Automatic Channel Allocation at each AP - no central control			
	Automatic Rogue AP Detection and Notification to NMS			
	Multi-BSS Multi-Hop Infrastructure Mesh [Meshed ESS] *			
	Enhanced Ad-Hoc Wireless Mesh for Multi-PNC coordination *			
	Power-level aware routing for WPAN UWB Chips *			
	Beacon Alignment for Simultaneous Operating Pico-nets *			
	Seamless roaming: includes voice traffic management			
	Location Sensing capability integrated into heart beat			
	 = Optional			

* no adequate alternatives exist today for these specific features, patents pending

Features Specific to WPAN

- Auto Discovery
- Self healing
- Dynamic load balancing

- Latency/Throughput control
- Power management
- Pro-active routing
- Multi-Channel/Zonal support
 - Multiple Pico-Net co-existence
 - Dynamic Beacon Alignment

- Low memory footprint
- Hardware agnostic
- Wireless protocol agnostic

Applications



- Home networking
- Wireless Ad-hoc networks

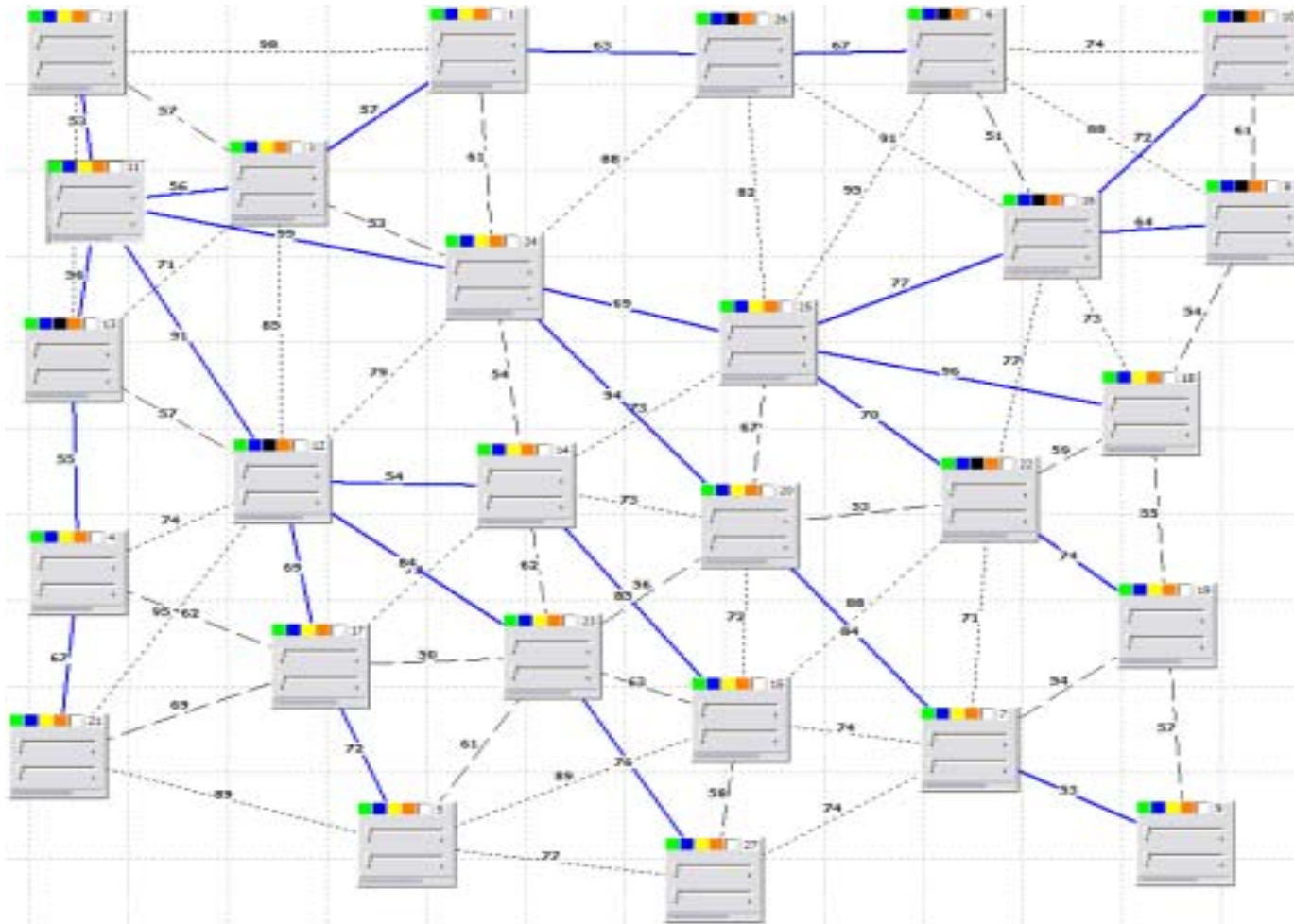

Scaleable, Redundant, Self-configuring, Self-Healing, Application aware

Live Demonstration Available

Live Demonstration

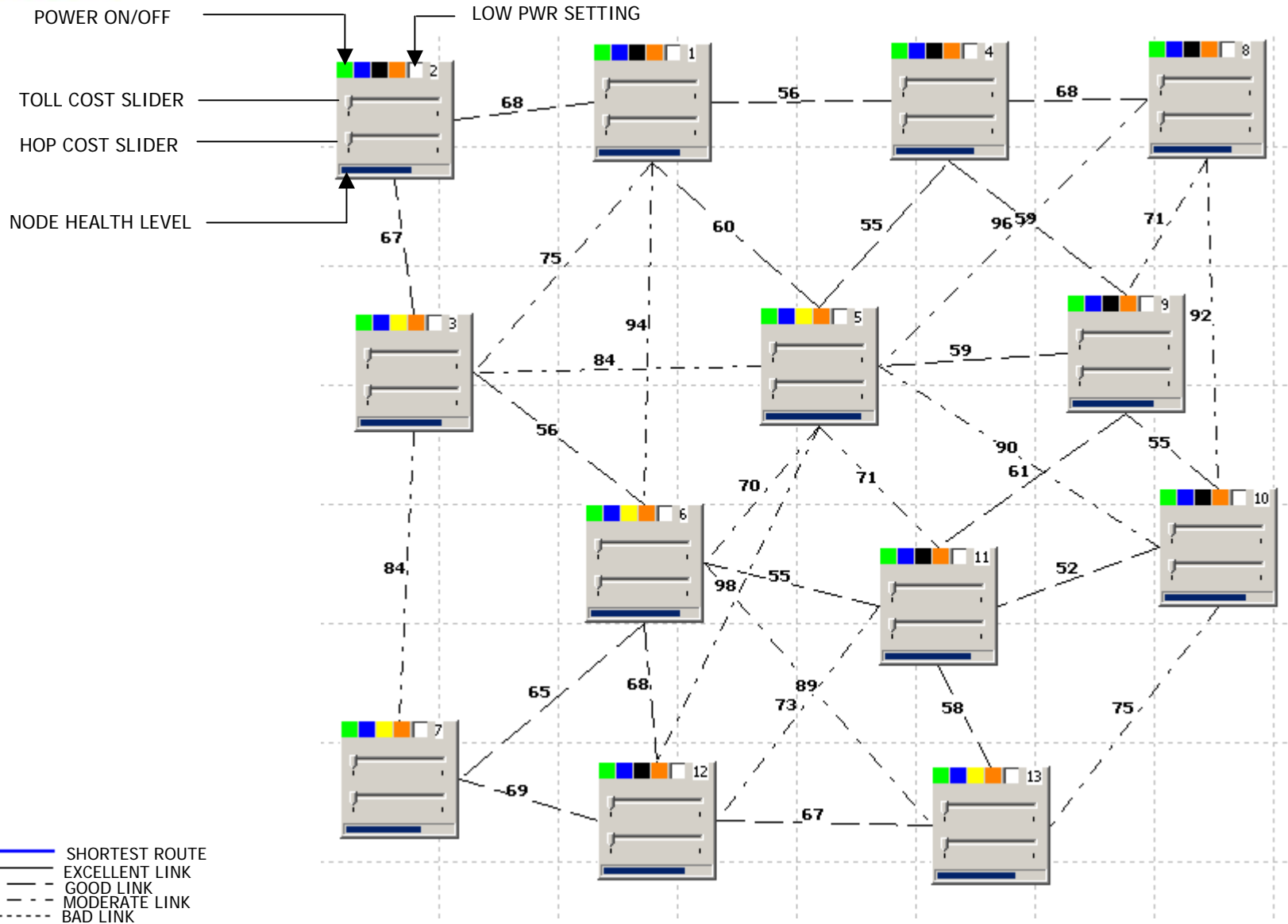

Low Power Setting

The low power switch enables the node to use routes that use the lowest power.

Toll Cost

Every device charges “toll” to forward packets of other devices. Using the toll cost slider, one can manually see the effects of change in toll cost. The devices automatically change the toll cost for load balancing purposes.

Hop Cost

Hop cost determines how much each hop costs a device, when it transmits packets via other devices. Low latency devices have a high hop cost.

Low Power Setting Alters Route

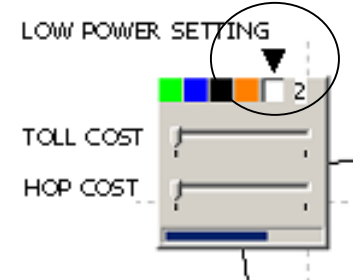
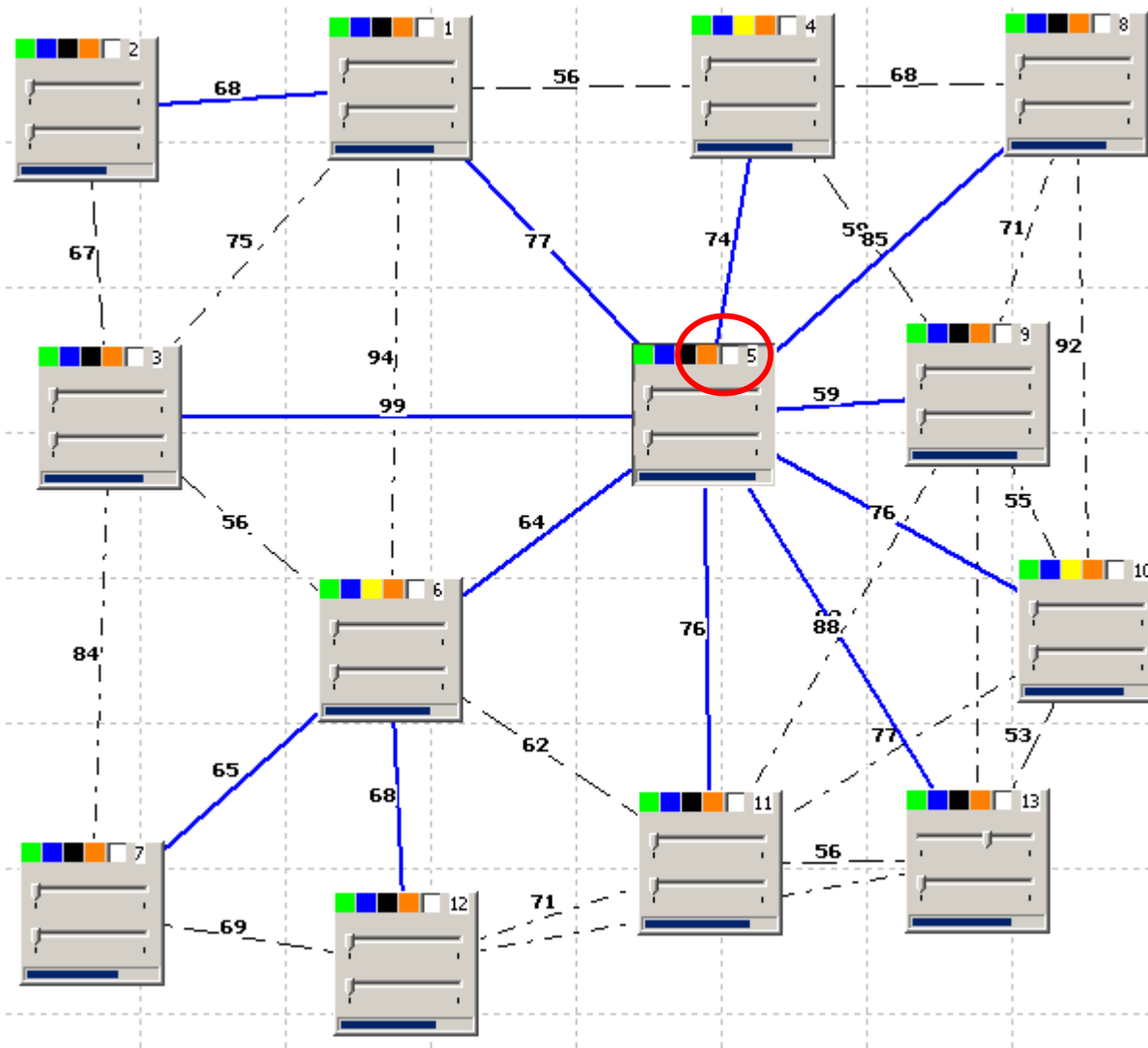

Auto Discovery

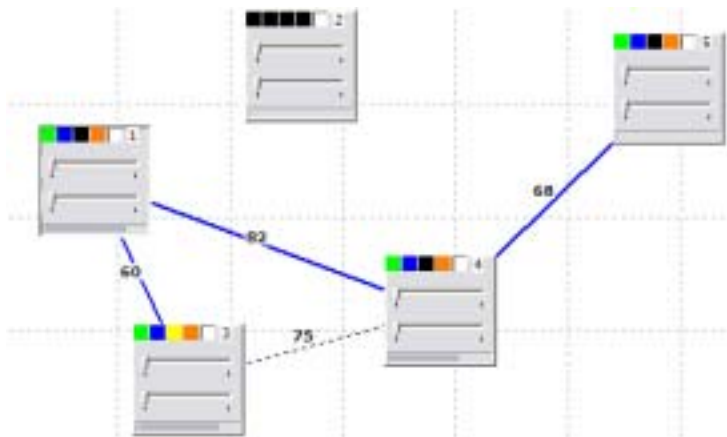

BEFORE

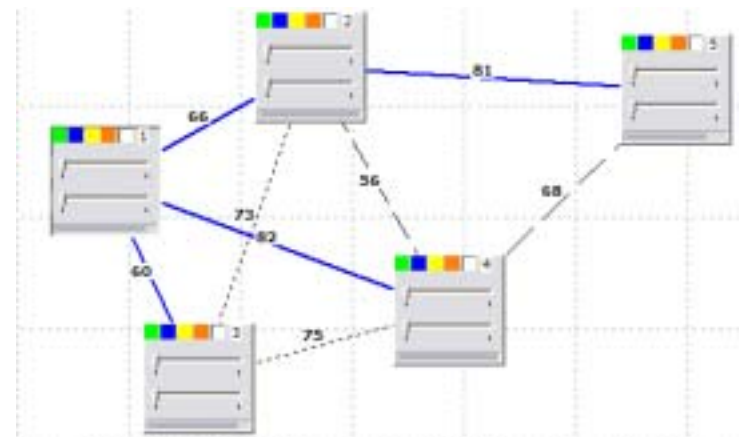

AFTER

- New devices are automatically discovered
- Routing tables automatically updated

Self Healing

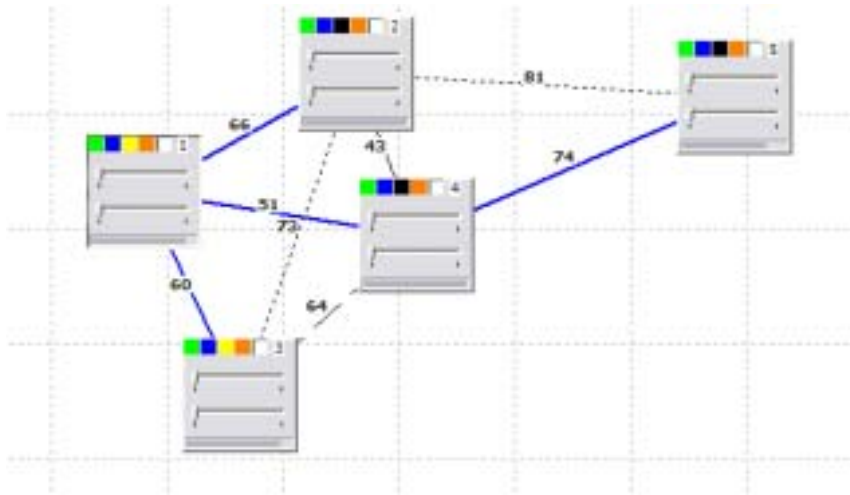

BEFORE

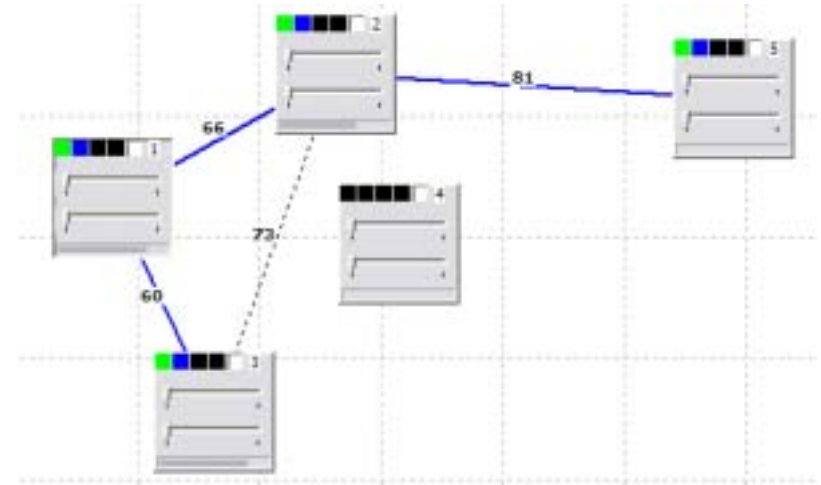

AFTER

- Failure of a node automatically causes route change

Load Balancing

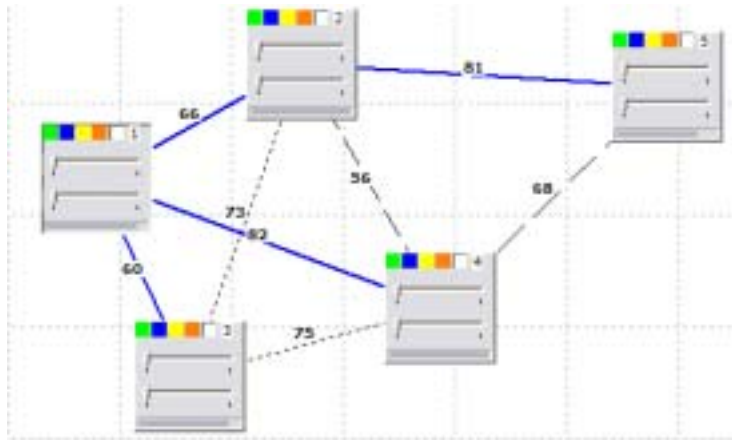

BEFORE

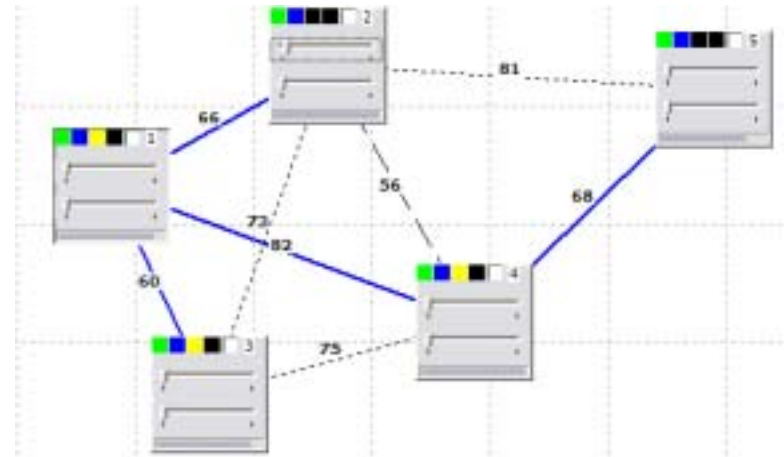

AFTER

- Nodes dynamically change their toll costs depending upon load.
- This automatically causes routes to change.

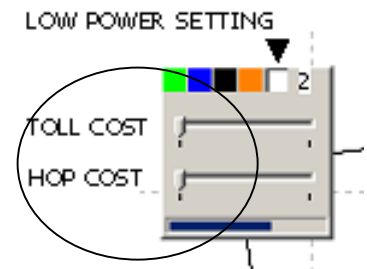

Latency/Throughput Control

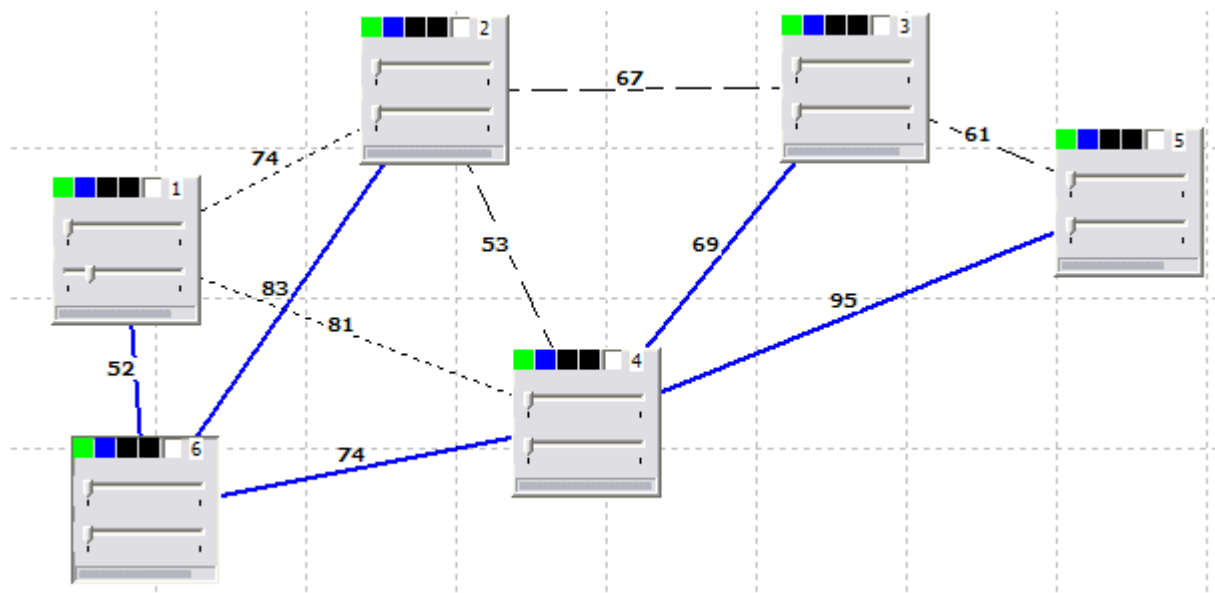

Node	Hop Cost	Toll	Neighbours	Health
1	200	0	3	84
2	0	0	4	92
3	0	0	3	84
4	0	0	5	100
5	0	0	2	76
6	0	0	3	84

- Node 6 is a normal device
- Talks to Node 5 via Node 4

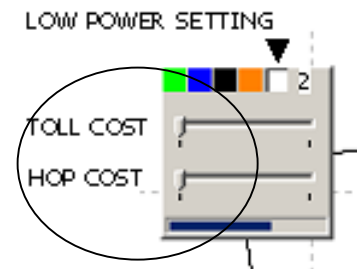

Latency/Throughput Control

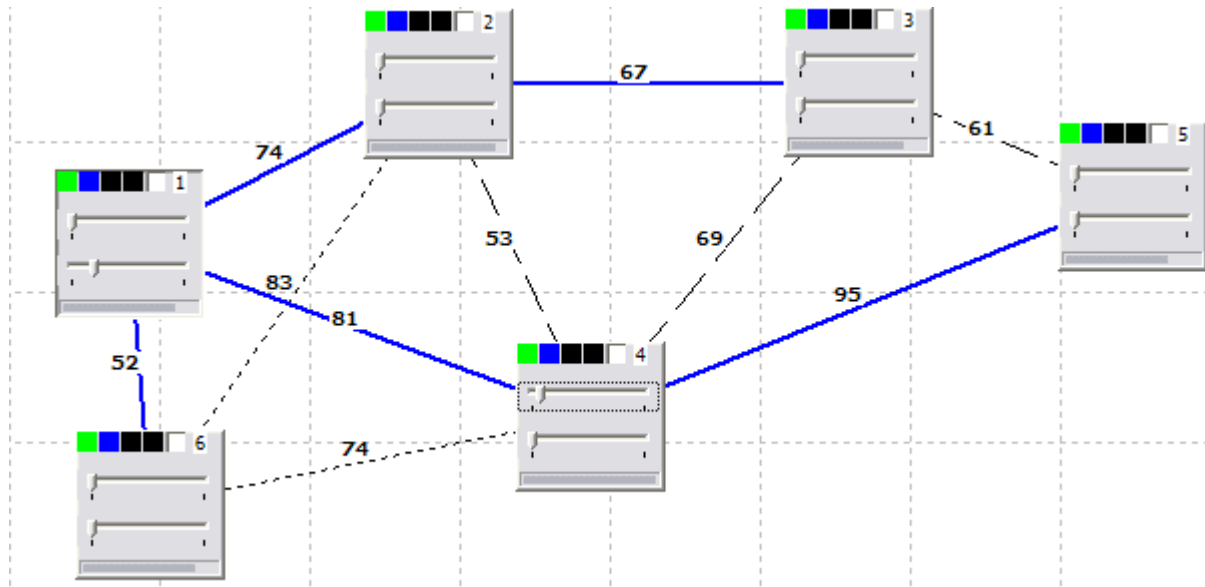

Node	Hop Cost	Toll	Neighbours	Health
1	200	0	3	84
2	0	0	4	92
3	0	0	3	84
4	0	71	5	100
5	0	0	2	76
6	0	0	3	84

- Node 4 increases Toll
- Node 1 still talks via Node 4

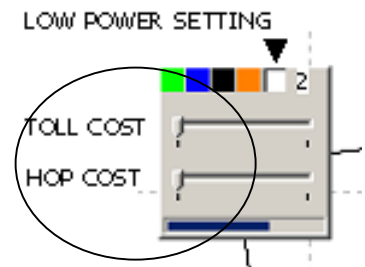

Latency/Throughput Control

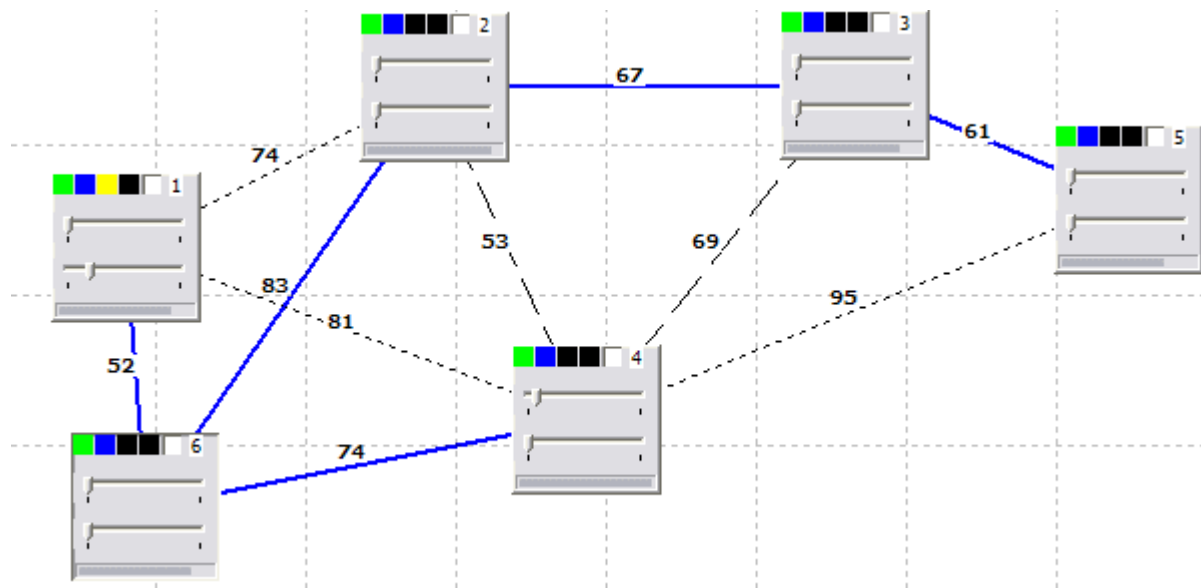

Node	Hop Cost	Toll	Neighbours	Health
1	200	0	3	84
2	0	0	4	92
3	0	0	3	84
4	0	71	5	100
5	0	0	2	76
6	0	0	3	84

- Node 6 switches route

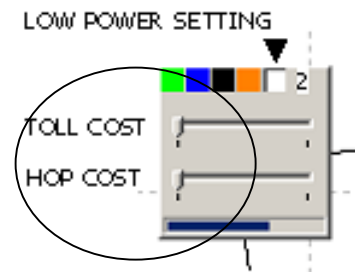

Managing Multiple Pico-Net Controllers

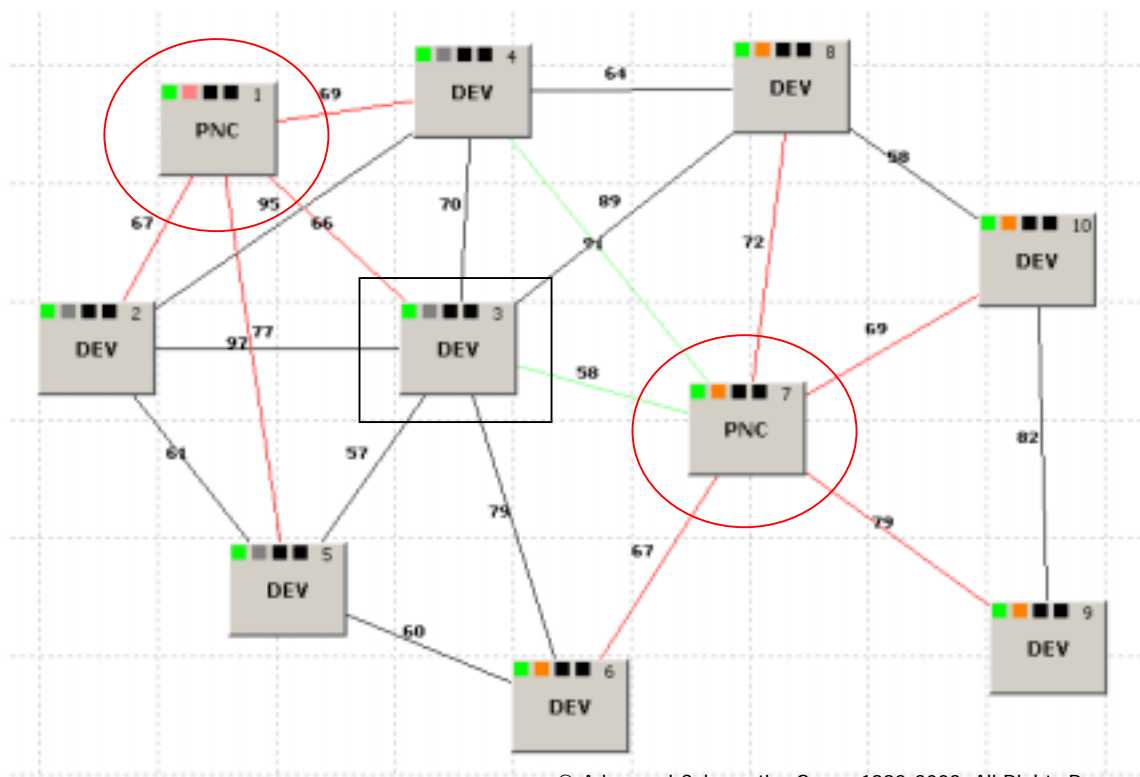

© Advanced Cybernetics Group 1992-2003. All Rights Reserved

- Some Devices in an 802.15.X may interact with multiple Pico-Net Controllers (PNC)
- Device 3 receives beacons from both controllers, possibly interfering with each other.
- Timing of PNC beacons and their CAP/CTA periods requires coordination

Heart Beat Based Beacon Alignment

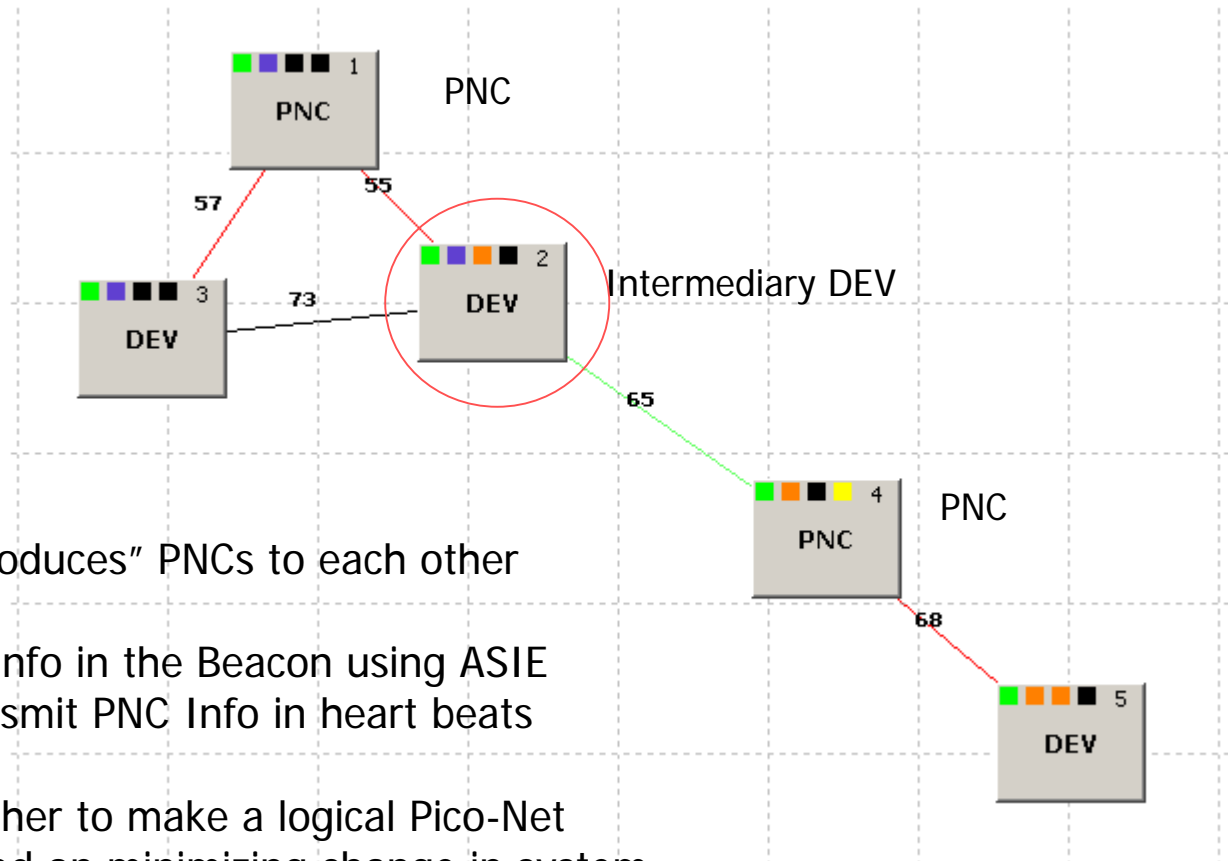

- Intermediary Device “introduces” PNCs to each other
 - PNCs transmit info in the Beacon using ASIE
 - Devices re-transmit PNC Info in heart beats
- One PNC aligns with another to make a logical Pico-Net
- Senior PNC selection based on minimizing change in system.

Heart Beat Based Beacon Alignment

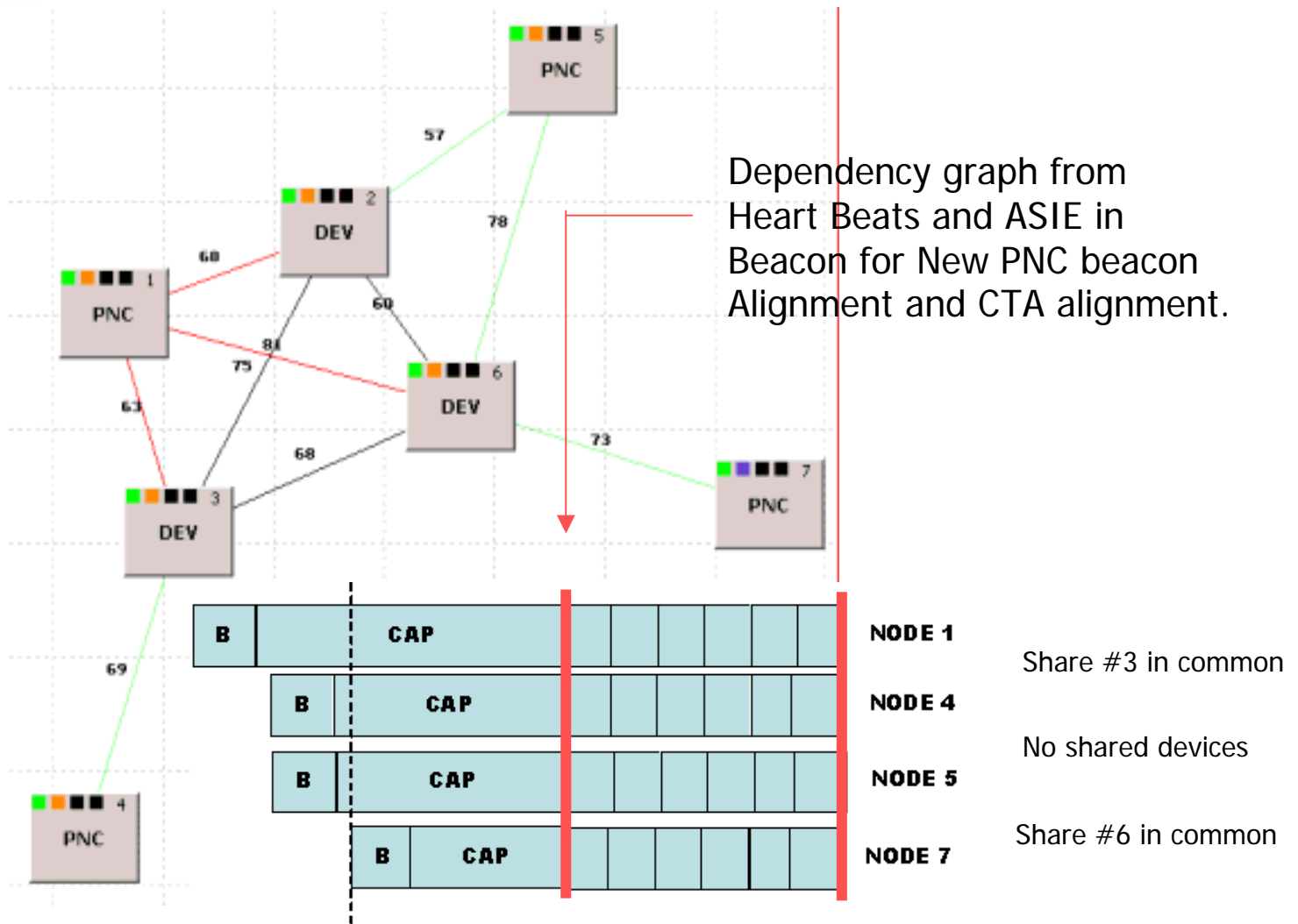

Dependencies identified and drive alignment algorithms

Demonstrable Implementation

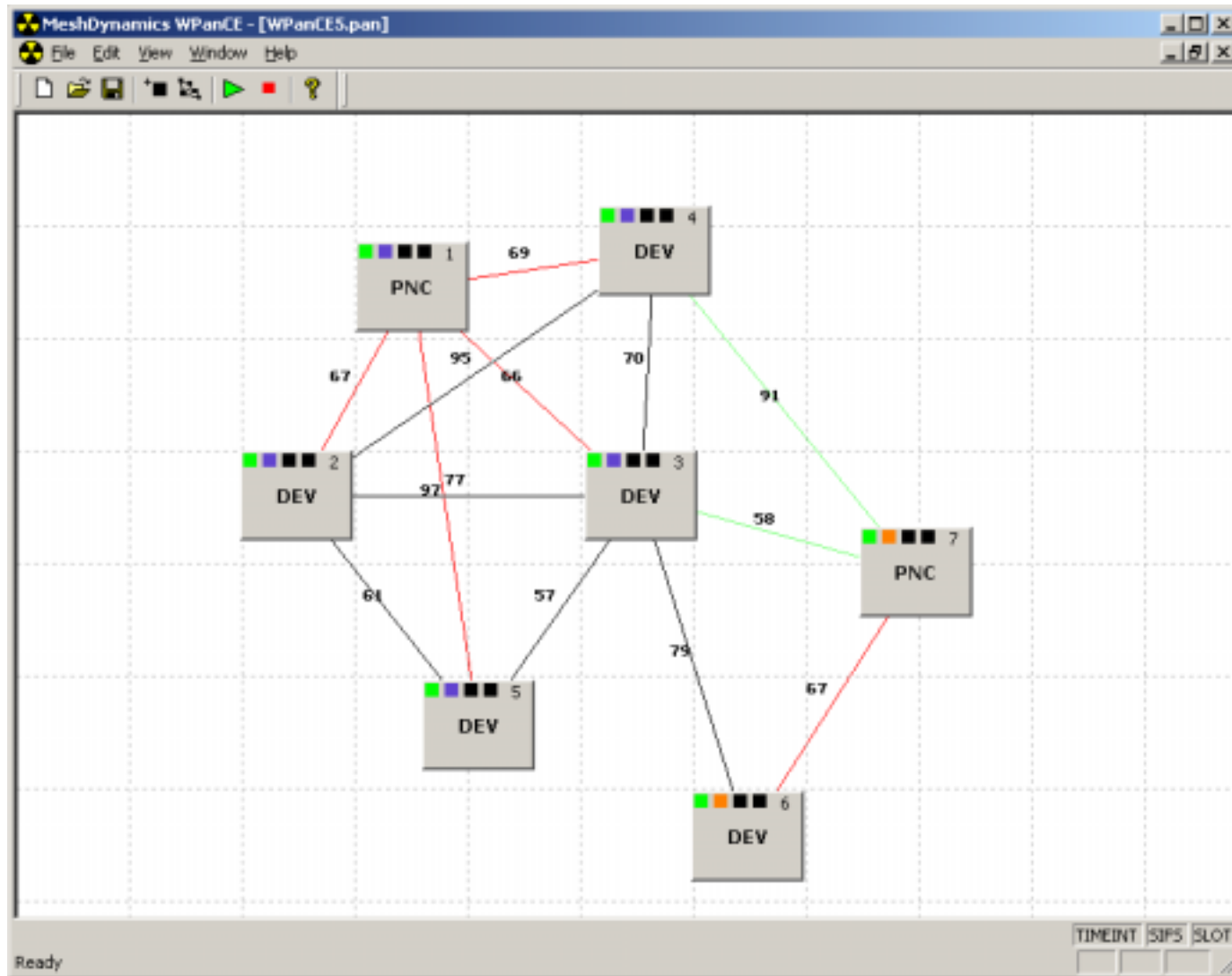

Competitive Advantages

- Competitors are “BOX” solutions
 - Solve only a subset of problems in specific domains
 - Not distributed, cost effective, scaleable approach
 - Not OEM software licensing model
 - Code large and complex, hardware specific
 - Code not seamlessly adaptable to 2,3,4 radios
 - Not radio and protocol agnostic
- We provide OEM ready SOFTWARE solutions
 - Reduced time to market, rights to patent
 - Offer customization and consulting services
 - Solutions are radio and protocol agnostic.
 - Solutions require no special client software
 - Solutions fit in 60Kb: use existing hardware